

## CHLORINATOR INFORMATION

PLEASE NOTE IN THE FOLLOWING CARD THE REGISTRATION DATA OF THE EQUIPMENT YOU HAVE PURCHASED, WHICH ARE FOUND ON THE SIDE LABEL.

THESE DATA WILL BE OF USE IF YOU WISH TO MAKE ANY ENQUIRY TO YOUR SUPPLIER

MODEL.....  
REF. ....  
VOLTAGE.....  
SERIAL NUMBER.....

## CONTENTS

<b>1 - GENERAL DESCRIPTION</b> .....	54
<b>1.1- EVO salt water chlorination equipment</b> .....	54
<b>1.2- Product range</b> .....	55
<b>1.3- Technical specifications</b> .....	56
<b>1.4- Recommendations and safety precautions</b> .....	57
<b>2 - PREPARING THE SWIMMING POOL</b> .....	58
<b>2.1- Adding salt to the water</b> .....	58
<b>2.2 Chemical balance of the water</b> .....	59
<b>3 - INSTALLATION OF THE EQUIPMENT</b> .....	60
<b>3.1- General considerations</b> .....	60
<b>3.2- Hydraulic connection diagram</b> .....	61
<b>3.2.1- EVO Series Equipment (EVoBASIC, EVoLOWSALT, EVoMg)</b> .....	61
<b>3.2.2- AUTO kit</b> .....	62
<b>3.2.3- ADVANCED kit (ORP)</b> .....	64
<b>3.2.4- PRO/2 kit (free chlorine) Optional in EVO equipment</b> .....	64
<b>3.2.6- CONDUCTIVITY Kit</b> .....	73
<b>3.3 - Electrical wiring diagram</b> .....	75
<b>4 - START-UP AND ADJUSTMENTS</b> .....	79
<b>4.1- EVO series equipment</b> .....	79
<b>4.2- Warning messages and alarms (EVO)</b> .....	92
<b>4.3- Operation time</b> .....	95
<b>4.4- Electrolysis cell life</b> .....	95
<b>5 - MAINTENANCE</b> .....	95
<b>5.1- Cleaning the electrolysis cell</b> .....	96
<b>5.2- Checking and maintenance of the Redox probe</b> .....	96
<b>5.3- Checking and maintenance of the pH probe</b> .....	97
<b>5.4- Checking and maintenance of the Amperometric probe</b> .....	97
<b>6 - GUARANTEE AND SERVICE</b> .....	99

## ATTENTION



Before installing the salt water chlorinator, please read this manual carefully. If you need to clarify any point or have any doubts, please contact your dealer.

## 1 - GENERAL DESCRIPTION

### 1.1- EVO salt water chlorination equipment

Thank you for purchasing our salt water chlorinator, which will enable you to enjoy your swimming pool in perfect conditions, without the need to add any chemical disinfectants.

The salt water chlorination system produces chlorine directly in the filtering installations by means of electrolysis of slightly salted water. "Free chlorine" (hypochlorous acid,  $\text{HClO}$ ) is produced which is a strong bactericide. Results are similar to the chemical products that are normally added.

Saline electrolysis is a reversible process, meaning that once active elements react with organisms present in the water, it reverts to common salt and water.

The equipment includes an electronic monitoring and regulation control and an electrolysis cell through which the pool water flows and which is installed in the filtering circuit return.

If the salt water chlorinator equipment is left to work permanently, it will not be necessary to change the swimming pool water for several years (8 to 15 depending on its use). You will therefore be collaborating with environment preservation policies and water management and saving.



## 1.2- Product range

You will find various models within our range, depending on its production and features.

### 1.2.1- EVO BASIC

- HClO production from 10 to 35g/h
- Operating modes: manual, automatic (by means of an **optional** ADVANCED kit), and semi-automatic (with **optional** temperature probe kit)
- pH reading and adjustment through the AUTO kit (**optional**).
- Advanced features and data display through an LCD screen.
- Connection for home automation system (optional CONNECT kit)

### 1.2.2- EVO Mg

- MgCl<sub>2</sub> production: 10, 25 and 35g/h
- Works with magnesium and common salt.
- Operating modes: manual, automatic (by means of an **optional** ADVANCED kit), and semi-automatic (with **optional** temperature probe kit)
- pH reading and adjustment through the AUTO kit (**optional**).
- Advanced features and data display through an LCD screen.
- Connection for home automation system (optional CONNECT kit)

### 1.2.3- EVO LOW SALT

- HClO production: 15, 20 and 30g/h
- Works with salt concentration as low as 1 to 2g/l
- Operating modes: manual, automatic (by means of an **optional** ADVANCED kit), and semi-automatic (with **optional** temperature probe kit)
- pH reading and adjustment through the AUTO kit (**optional**).
- Advanced features and data display through an LCD screen.
- Connection for home automation system (optional CONNECT kit)

## 1.3- Technical specifications

### 1.3.1 Equipment

Modelos	EVoBasic-10	EVoBasic-15 EVoMg-15	EVoBasic-20 EVoMg-20	EVoBasic25 EVoMg-25	EVoBasic-35 EVoMg-35
<b>Supply voltage</b>	230Vac 50/60Hz	230Vac 50/60Hz	230Vac 50/60Hz	230Vac 50/60Hz	230Vac 50/60Hz
<b>Chlorine production g/hour</b>	10	15	20	25	35
<b>Max. power</b>	75W	112.5W	150W	187.5W	263W
<b>Cell current</b>	10A	15A	20A	25A	35A
<b>Dimensions</b>	280x250 X135mm	280x250 X135mm	280x250 X135mm	280x250 X135mm	280x250 X135mm
<b>Weight</b>	4Kg	4Kg	4Kg	4Kg	4Kg
<b>Protection</b>	IP65	IP65	IP65	IP65	IP65
<b>Max. Room Temp.</b>	40 °C	40 °C	40 °C	40 °C	40 °C

Modelos	EVoBasic15LS	EVoBasic20LS	EVoBasic30LS
<b>Supply voltage</b>	230Vac 50/60Hz	230Vac 50/60Hz	230Vac 50/60Hz
<b>Chlorine production g/hour</b>	15	20	30
<b>Max. power</b>	187.5	263W	380W
<b>Cell current</b>	25A	35A	17.55A
<b>Dimensions</b>	280x250 X135mm	280x250 X135mm	280x250 X135mm
<b>Weight</b>	4Kg	4Kg	4Kg
<b>Protection</b>	IP65	IP65	IP65
<b>Max. Room Temp.</b>	40 °C	40 °C	40 °C

### 1.3.2 Common features in all EVO equipment

- Adjustment of chlorine production by switched mode power supply
- Power supply performance >90%
- Automatic switch-off owing to lack of water flow
- Automatic switch-off owing to the accumulation of gas in the cell, with automatic restart once the water flow is restored.
- Automatic voltage adjustment depending on the concentration of salt and the temperature, keeping continuous chlorine production.
- Automatic cleaning cycle of electrodes.
- Automatic restart in the event of supply failure.

### 1.4- Recommendations and safety precautions

- The equipment should always be installed by qualified staff.
- Disconnect the equipment from the mains before performing any assembly or maintenance operation.
- **Make sure that the electrical installation has all compulsory protection elements (circuit breaker and differential switch) in perfect condition.**
- **It is important to ensure that the supply cables of the electrolysis cell are tightly connected, otherwise the equipment could overheat and break down.**
- Ensure that the heatsink wings (in the rear part of the equipment) are not blocked and that air can easily circulate through them.
- All the BSV equipment incorporate protection systems against short circuits in the cell, absence of water detector and other safety systems that give an acoustic and visual alarm in the event of any anomaly. However, for optimum results, you should ensure the correct hydraulic operation of your swimming pool.
- Equipment housing has IP65 protection. However, it is highly recommended not to install the equipment directly exposed to sunlight.
- Corrosive environments may reduce the lifespan of the equipment. Do not leave open containers with acids near the equipment.



## 2 - PREPARING THE SWIMMING POOL

### 2.1- Adding salt to the water

To ensure that the chlorinator works correctly, a small amount of salt should be added and the pH level should be suitable.

The recommended **salt and pH** levels are the following:

	Salt Concentration (g/l)	Ph
EVoBASIC	4 a 6	7,1 a 7,4
EVoLOW SALT	1 a 2	
EVoMg	4 a 6 (*)	

(\*) Magnesium chloride

Although the equipment will start to operate with lower amounts of salt, the optimum production of salt will be reached with concentrations of over 4kg/m<sup>3</sup>. We recommend a concentration of 5Kg/m<sup>3</sup> to offset small losses of salt occurring when cleaning the filter, the effect of rainfall, etc.

To calculate the salt to be added, multiply the total m<sup>3</sup> of your swimming pool x 5.

**Example:** *A swimming pool measuring 9m in length x 4.5m in width x 1.6m in depth, using an EVoBASIC*

*9 x 4.5 x 1.6 = 64.8 cubic meters. 64.8 x 5 = 324 Kg of salt to be added.*

We recommend using salt that is especially prepared for use in salt water chlorination installations, as it is especially prepared for rapid dissolution and to achieve optimum results. You can find it at retailers specializing in swimming pool products.

#### **ATTENTION**



When adding salt to the swimming pool, first disconnect the chlorinator (position **OFF**), and start-up the filter for 3 or 4 hours, in order for the salt dissolving and not to overload the equipment. Once dissolved, switch on the chlorinator.

It is advisable to add salt to the swimming pool gradually, in 2 or 3 times so as not to exceed the recommended amount. Excess salt can overload the chlorinator, in which case it will automatically stop working and water will have to be added to reduce the concentration.

We also recommend not to add salt near the drain, to avoid undissolved salt from circulating in the water circuit.

## 2.2 Chemical balance of the water

The effectiveness of chlorination and the quality of water for healthy bathing, depends largely on the pH of the water. Therefore, it should be checked regularly and adjusted as necessary.

There are other parameters which should be considered for the correct operation of the salt water chlorinator. We recommend an in-depth analysis of the water when installing a salt water chlorinator.

<b>Parameter</b>	<b>Minimum Value</b>	<b>Maximum Value</b>
PH	7.0	7.8
FREE CHLORINE (mg/l)	0.5	2.5
COMBINED CHLORINE (mg/l)	--	0.6
TOTAL BROMIDE (mg/l)	3.0	6.0
BIGUANIDE (mg/l)	25	50
ISOCYANURIC ACID (mg/l)	--	<75
OZONE (GLASS) (mg/l)	--	0
OZONE (before)	0.4	--
TURBIDITY (NTU)	--	<1
OXIDES (mg/l)	--	<3
NITRATES (mg/l)	--	<20
AMMONIA (mg/l)	--	<0.3
IRON (mg/l)	--	<0.3
COPPER (mg/l)	--	<1.5
ALKALINITY (mg/l)	100	160
CONDUCTIVITY (us/cm)	--	<1700
TDS (mg/l)	--	<1000
HARDNESS (mg/l)	150	250

## 3 - INSTALLATION OF THE EQUIPMENT

### 3.1- General considerations

- Place the chlorine cell in a vertical position with electrical connections facing upwards. If this is not possible, it can be assembled in a horizontal position, ensuring that the small auxiliary electrode faces upwards.
- Place the chlorination cell in the highest position possible of the purification circuit and always after the filter.
- If possible, it is recommended to install the cell with a by-pass system with its corresponding shut-off valves. This is to facilitate maintenance of the cell.
- Do not place the REDOX probe (OPTIONAL) near the chlorinator cell, as faulty readings could be made owing to the proximity of the electrolysis circuit. Always try and ensure that the filter is between both and that there is **at least half a meter** of water flow between the probe and the chlorination cell.

The REDOX probe should be installed after the filter, but if with this layout it is not possible to keep a minimum distance from the cell, it should be assembled before the filter. In this case more frequent maintenance of the probe is required (see paragraph 5.2 below in "Maintenance").

- A **good earth connection is essential**. Use a differential relay with max. 30mA of sensitivity.

**If a good quality earth connection is not available, place an earth connection kit between the electrolysis cell and the redox probe.**  
**OPTIONAL KIT**

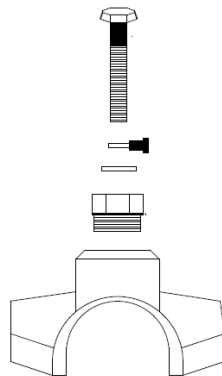

## 3.2- Hydraulic connection diagram

### 3.2.1- EVO Series Equipment (EVoBASIC, EVoLOWSALT, EVoMg)

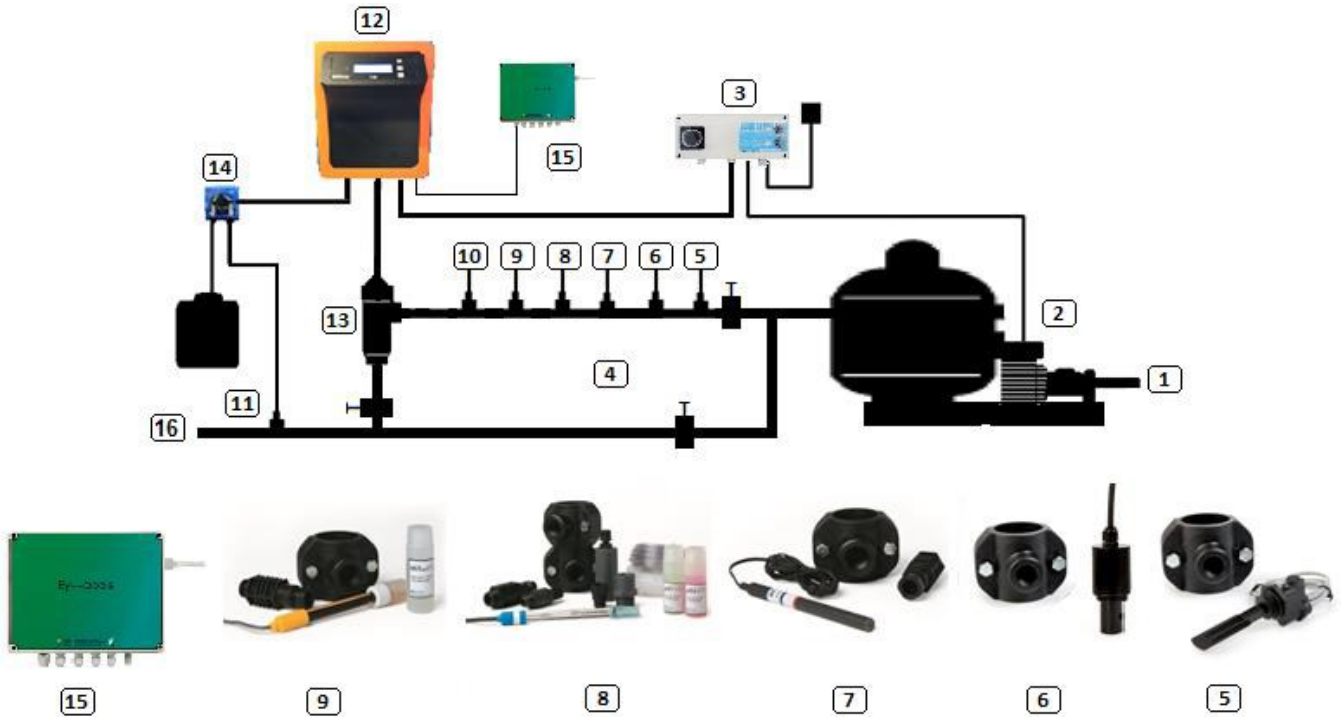

1. From the swimming pool.
2. Filtration
3. Electrical Panel
4. Bypass
5. Flow Switch (optional)
6. Conductivity probe (optional)
7. Temperature probe (optional)
8. pH probe, included in AUTO kit (optional)
9. Redox probe, included in ADVANCED kit (optional)
10. Ground kit (optional)
11. Acid injector
12. EVOBASIC chlorinator
13. Electrolysis cell
14. pH pump
15. Domatic CONNECT kit (optional)
16. To the swimming pool.

### 3.2.2- AUTO kit

The AUTO kit (pH measure and regulation) can be added to any EVO series unit. The following figures show the parts of the kit, plus an installation diagram.

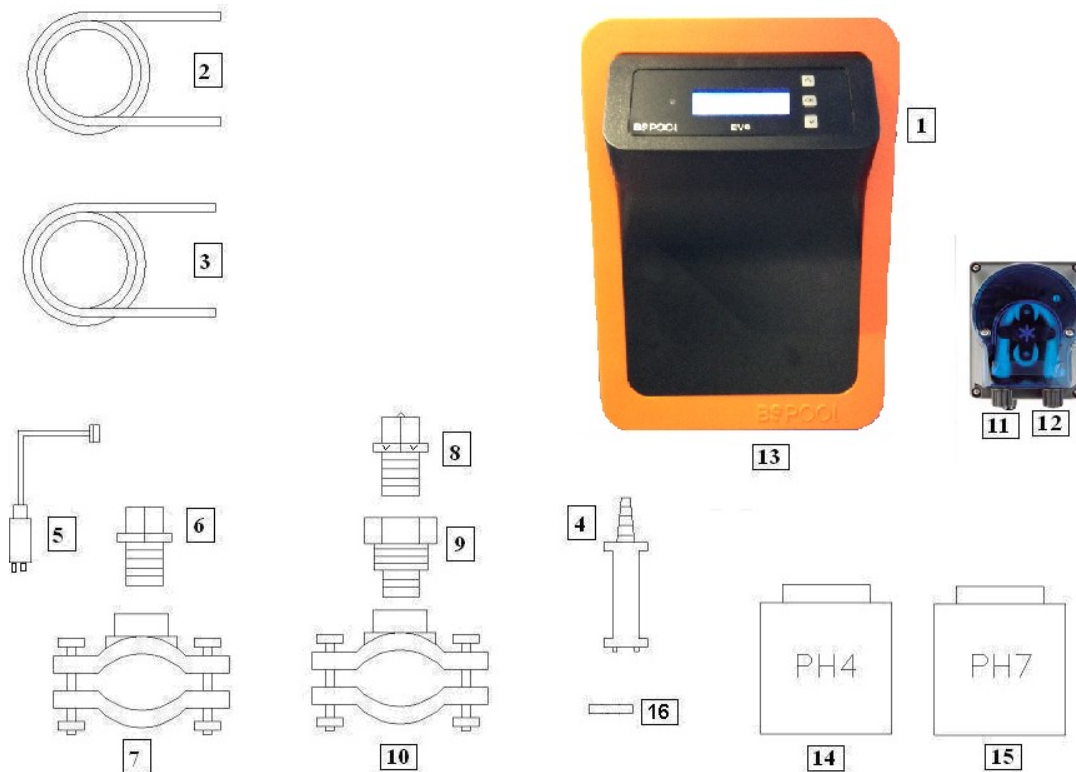

#### 3.2.2.1- Parts

- 1- EVO Equipment
- 2- Suction Tube (flexible)
- 3- Injection Tube (rigid)
- 4- Suction filter (place vertically on the bottom of the acid container)
- 5- pH Probe
- 6- Probe Holder
- 7- Flange
- 8- Injector (place with the arrow facing downwards)
- 9- Pipe nipple 3/8,1/2
- 10- Flange
- 11- Acid inlet (suction tube)
- 12- Acid outlet (injection tube)
- 13- pH probe connector (BNC)
- 14- pH4 calibration liquid
- 15- pH7 calibration liquid
- 16- Rubber cap for calibration



### 3.2.2.2- Connection of pH kit

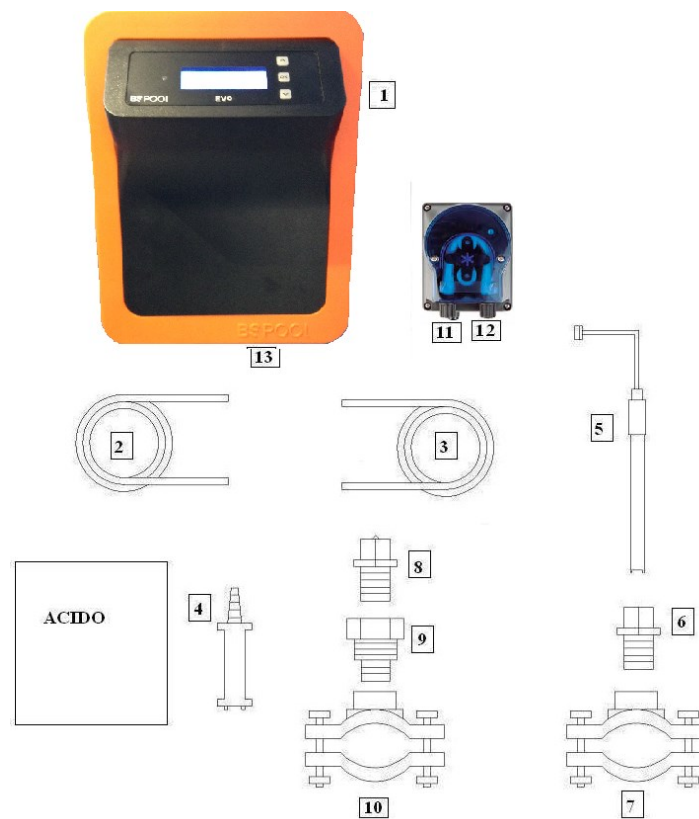

Once the equipment (1) is installed, the following connections should be done.

- 1- Place the flange (10) in the pipe as indicated in the hydraulic connection diagram. The flange (10) corresponds to the injector and should be connected after the electrolysis cell.
- 2- Place the flange (7) in the pipe as indicated in the hydraulic connection diagram. The flange (7) corresponds to the PH probe and should be connected after the electrolysis cell and before the filter.
- 3- Connect one end of the suction tube (2) to the PH control inlet (11).
- 4- Connect the other end of the suction tube (2) to the suction filter (4).
- 5- Place the suction filter (4) inside the ACID drum.
- 6- Connect one end of the suction tube (3) to the PH control inlet (12).
- 7- Place the pipe nipple (9) inside the flange (10).
- 8- Place the injector (8) inside the pipe nipple (9).
- 9- Connect the other end of the injection tube (3) to the injector (8).
- 10- Place the probe holder (6) inside the flange (7).
- 11- Place the PH probe (5) inside the probe holder (6).
- 12- Place the PH probe (5) connector in the BNC connector (13) of the equipment.

### 3.2.3- ADVANCED kit (ORP) (OPTIONAL in EVO series equipment)

The equipment continuously measures the bactericide level of water through this probe, by means of an "ORP" probe. Simply adjust the required level and the equipment automatically maintains the level of disinfection by adjusting the production of chlorine to the real needs of the swimming pool.

The screen shows the "Redox" level (bactericide capacity) present in the swimming pool.

The ORP (Oxidation Reduction Potential) is the electrical voltage that indicates the oxidation capacity or reduction of a solution. In swimming pools, the oxidation capacity is directly related to the bactericide power of the water, which is directly related to the concentration of free chlorine in the pool.

This probe enables you to adjust the equipment in AUTOMATIC operating mode.

#### 3.2.3.1- Parts

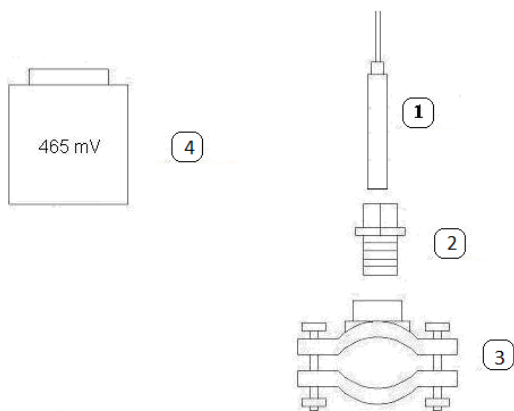

- REDOX Probe
- 6- Probe-Holder
- 7- Flange
- 4- Reference liquid 465mV.



### 3.2.4- PRO/2 kit (free chlorine) Optional in EVO equipment

The amperometric measurement kit, allows to obtain a ppm free chlorine Reading from your swimming pool. This sensor is swimming a 3-electrode header, which is separated from the water through a membrane. This ppm measure has a low dependency of pH and isocyanuric acid, and it can be also installed in sea water swimming pools (this option to be asked to BSV Electronic). Please follow carefully the installation, calibration and maintenance instructions to ensure a perfect setup of the kit.

### 3.2.4.1 – Kit content

#### 3.2.4.1.1- Probe Holder

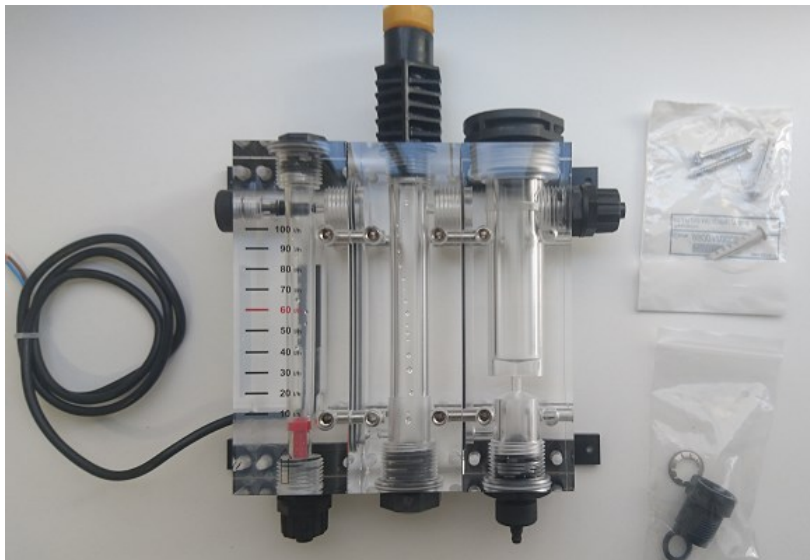

#### 3.2.4.1.2- Free Chlorine Probe

Includes

- CC1 Probe
- Membrane (Included in the header)
- Protection cap
- ECC1.1/GEL Electrolyte
- Abrasive paper



### 3.2.4.2- Technical specification

TECHNICAL SPECIFICATION	
Measure	Free chlorine, low pH dependency
Technology	Membrane. Potentiostatic 3-electrode header
Electronics	Embedded in the probe. 4-20mA output
Supply	12 to 30 VDC (10mA)
CL measure range	0.01 to 10.0 ppm
Measure deviation	approx. 3% every month
Operation temperature	0 to 45°C
Storage temperature	0 to 55°C
Operation maximum pressure	0.5 bar. Water hammer effect must be avoided.
pH range	4 to 12
Calibration	Directly on BSV control panel
Maximum time without CL on water	24h
Maintenance period	Water test: Minimum once a week
	Header-membrane change: Once a year
	Electrolyte change: Every 3-6 months, depending on the quality of the water

### 3.2.4.3- Installation

Please, carefully follow the recommendations regarding probe installation in order to ensure its proper operation:

#### 3.2.4.3.1- Hydraulic installation

Attach the probe holder to the wall by means the screws and wall plugs included in the box.

Ensure that the probe is correctly leveled.

As shown in the following Picture, the water inlet is in the lower left part of the probe holder, while the water outlet is in the upper right side of the probe holder.

In case a pH probe must be installed, it can be placed in the central part of the probe holder, removing the yellow cap and install the pH probe.

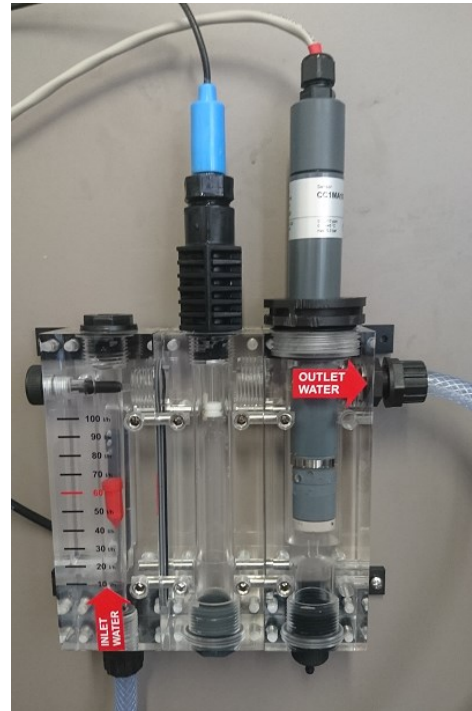
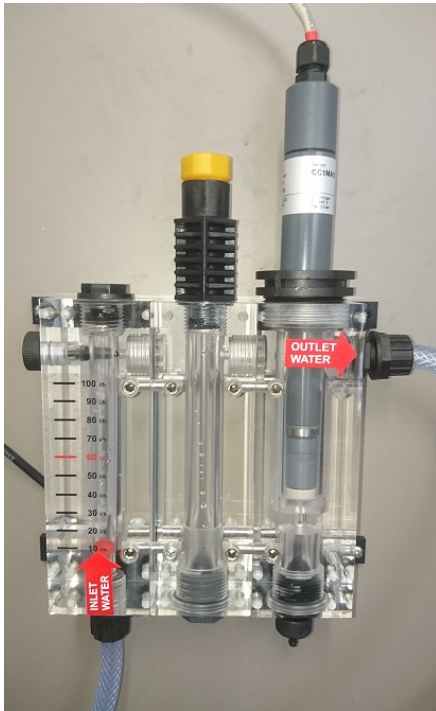

### **Additional recommendations:**

- If possible, install a hose valve at input, and another one at output to ease the cleaning and maintenance tasks.
- The probe holder water inlet can be connected after the filter, but then a good maintenance of the filter cleaning must be ensured, otherwise the measure can be affected by the chlorine consumption inside the filter.
- As an alternative, the inlet can be connecter before the filter, but then it is strictly necessary to install a specific cartridge filter to avoid the probe contamination.

### **3.2.4.3.2 Probe set up**

Before installing the probe, it is necessary to fill the cap with electrolyte. Please, follow carefully the following steps:

- 1) Unscrew the header cap from the sensor body and keep both parts in a clean and stable surface.  
**Important:** Don't touch the membrane and the gold electrode, they could be contaminated.
- 2) Fill the header cap with the supplied electrolyte. Fill it gently to avoid creating bubbles.



- 3) Caution:** Before screwing again the header cap to the sensor body, the silicone ring must be removed, uncovering the small hole shown in the following picture:



**Please, take care that this step is done correctly, otherwise the header membrane could be damaged, and will be out of warranty.**

- 4) Screw the header cap to the body of the probe. The excess of electrolyte will leak out across the small hole and the upper part of the cap. Use a cloth or blotting paper to clean it.

**Important: Ensure to fully screw the header cap.**

- 5) Put the silicone ring to its original position, in this way, the small hole will be covered again with the silicone ring.

### 3.2.4.3.3 Electrical connection

Before installing the probe on the probe holder, connect the supplied cable as follows:

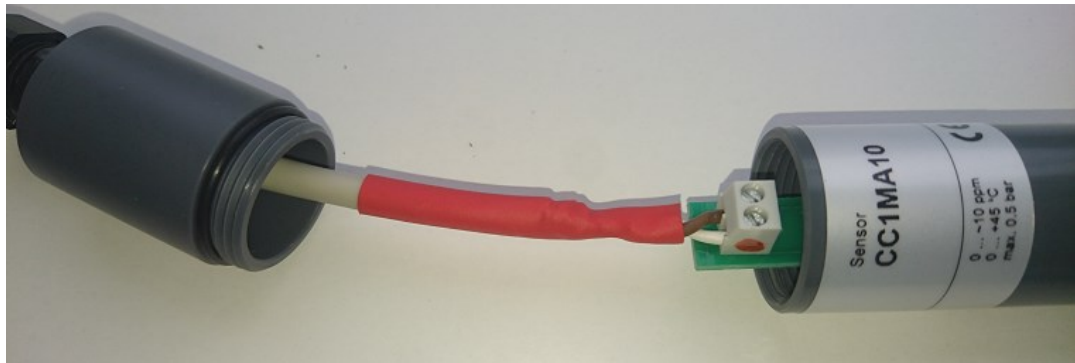

- Connect the white cable to the (+) input, it has a red or blue mark in the right side.
- Connect the dark cable to the (-) input.
- Once the connection is done, screw the cap and the cable gland.

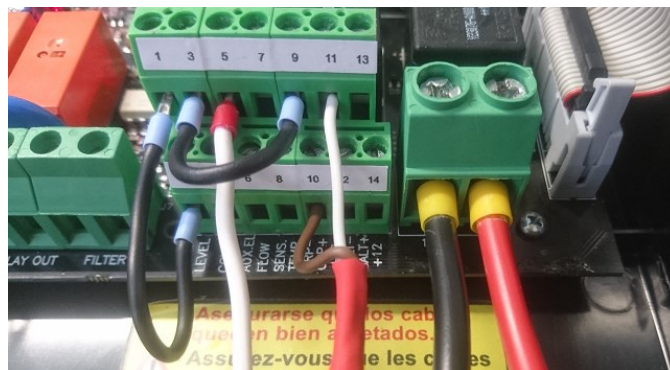

- Connect the cable to the unit as follows:
  - White cable: Input 11
  - Dark cable: Input 10
  - A cable bridge must be done between inputs 9 and 3.

### 3.2.4.3.4 Calibration

- 1) Install the probe on the probe holder. Use a tool to ensure the sensor is correctly tightened.
- 2) Switch the filtration pump on and adjust the water flow. The red flow indicator must be floating in the mid part of the indicator:

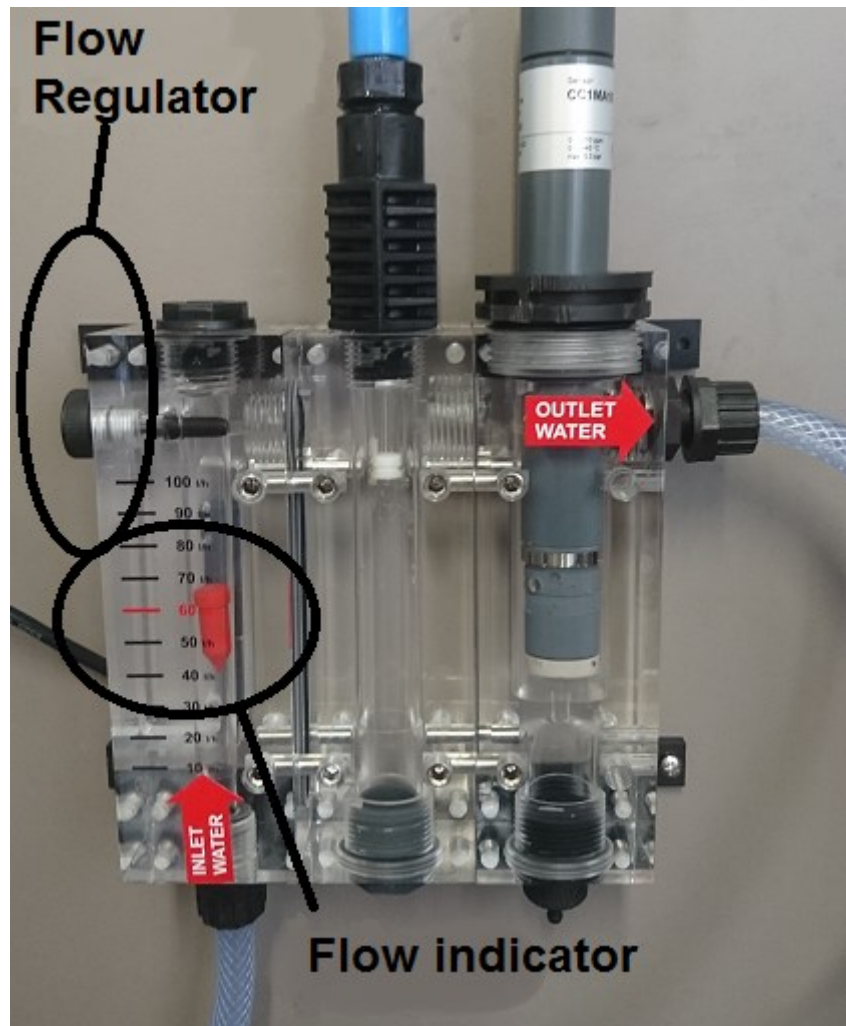

- 3) Switch on the electrolysis / dosing System. The CL reading will slowly increase and will be stable after some minutes.

**Note:** When the probe is switched on for the first time, the stabilization time could take longer than usual. In any case, it is recommendable to wait for at least 3 hours before making a first calibration.

- 4) Calibration

Wait until the CL reading is stable. If a difference between the display reading and the water testing by means of DPD-1 testing is observed, perform a calibration as follows:

- a. DPD-1 test. Take a water sample from the small plastic tap placed at the bottom part of the probe holder.



- b. Chlorine Menu -> Select "calibration" and press OK. Wait until the reading is stable:

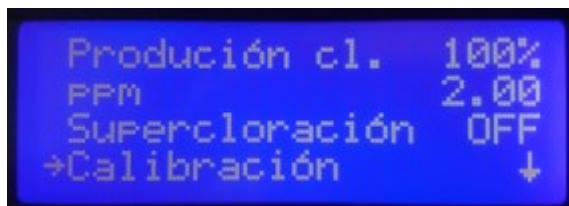

- c. Adjust the real value obtained by means of DPD-1 test.



- d. Return to the main screen. The current CL value will match with the value obtained from DPD-1 test.

### 3.2.4.3.5 Probe maintenance

Please, carefully read the following maintenance instructions for your PRO/2 Kit.

The maintenance periods are illustrative, they are depending on factors such as the quality of the water and the installation maintenance, especially with the filtration system.

**Weekly Maintenance:** Analyze the water from your swimming pool and if necessary, calibrate the free chlorine probe as shown on the 3.4 chapter.

**Twice a year (depending on the installation):** Replace the electrolyte.

**Once a year:** Replace the header (membrane).

How to replace the electrolyte and the header.

- 1) Remove the probe from the probe holder
- 2) Unscrew the header and remove the old electrolyte. Handle it carefully to avoid damaging the membrane.
- 3) Clean the Sharp point of the probe using the supplied abrasive paper. Please do it carefully, without an excessive pressure.



- 4) Carefully wash the header with tap water, and fill it again with new electrolyte. In case of the header needs to be replaced, discard the used an install a new one.
- 5) Remove the silicone ring, uncovering the small hole.
- 6) Completely screw the header, cleaning the excess of electrolyte, and place again the silicone ring to its place.
- 7) Install the probe with the probe holder. Calibrate it after 2-3 hours working.

### 3.2.5- NTC/1 kit (OPTIONAL) for EVO units

The temperature probe kit enables you to take a reading of the water temperature. Once the probe has been connected, the temperature will be displayed in the main screen.

By installing this kit, you will also be able to use the semi-automatic control mode. More details on this mode can be found on the 4.2 chapter in this manual.



### 3.2.6- CONDUCTIVITY Kit

The Conductivity Kit from BSPOOL performs a continuous measurement of your Swimming pool's water chloride. It is specially suitable to work with salt water chlorination Systems, and it will allow to know the salt concentration in the water, and also the electrolysis cell condition.

This sensor is been designed to work with BSPOOL Systems exclusively. In order to confirm the compatibility with your BSPOOL chlorinator model, please, ask to your distributor.



#### 3.2.6.1 Technical characteristics

- Sensor technology: Inductive, with temperature compensation
- Measurement range: 0 to 10g/l
- Resolution: 0,1g/l
- Supply: 12V DC

#### 3.2.6.2 Installation

##### 3.2.6.2.1 Hydraulic installation

- This sensor must be installed after your Swimming pool's filter, before the electrolysis cell. The minimum distance between the sensor and the electrolysis cell is 50cm.
- Install a 1"1/4 flange (not supplied) according with the pipe diameter where it will be installed.



### 3.2.6.2.2 Wire connection

Once the conductivity sensor is installed, should be connected to the electrolysis unit as follows:

- Brown wire (Supply): Connect to #14 label.
- Green wire (Measure): Connect to #13 label.
- White wire (Temperature): Connect to #8 label.
- Black wire (GND): Connect to #12 label.

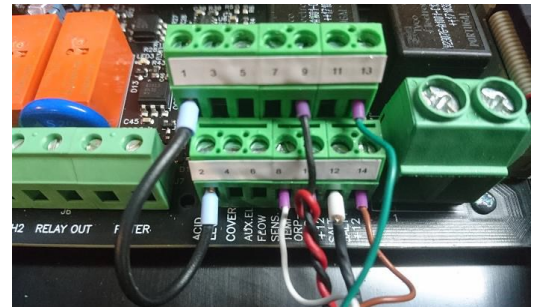

### 3.2.6.3 Operation and adjustment

Once the conductivity sensor is connected, the chlorinator will detect it automatically.

The main screen will show the measure, and also any warning related with the lack or too much salt conditions:

#### EVO y PRO units

- Lack of salt: Measure < 4g/l
- Too much salt: Measure > 8g/l

#### Equipos LOW SALT:

- Lack of salt: Measure < 1g/l
- Too much salt: Measure > 2g/l



### 3.2.6.3 Calibration and maintenance

The conductivity sensor comes already calibrated, however, it is possible to Access to a calibration menu in case that a measurement fine tuning would be required. Use an external measure system and then set the value in the salt adjust menú. Press OK to confirm the new calibration.

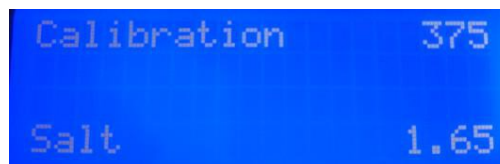

This sensor does not require any special maintenance. However, if an incorrect value is observed, an visual inspection of the measure head is recommended, in order to detect any strange body which could be interfering with the correct operation.

### 3.3 - Electrical wiring diagram

#### 3.3.1- EVO series equipment (EVoBASIC, EVoLOWSALT, EVoMg)

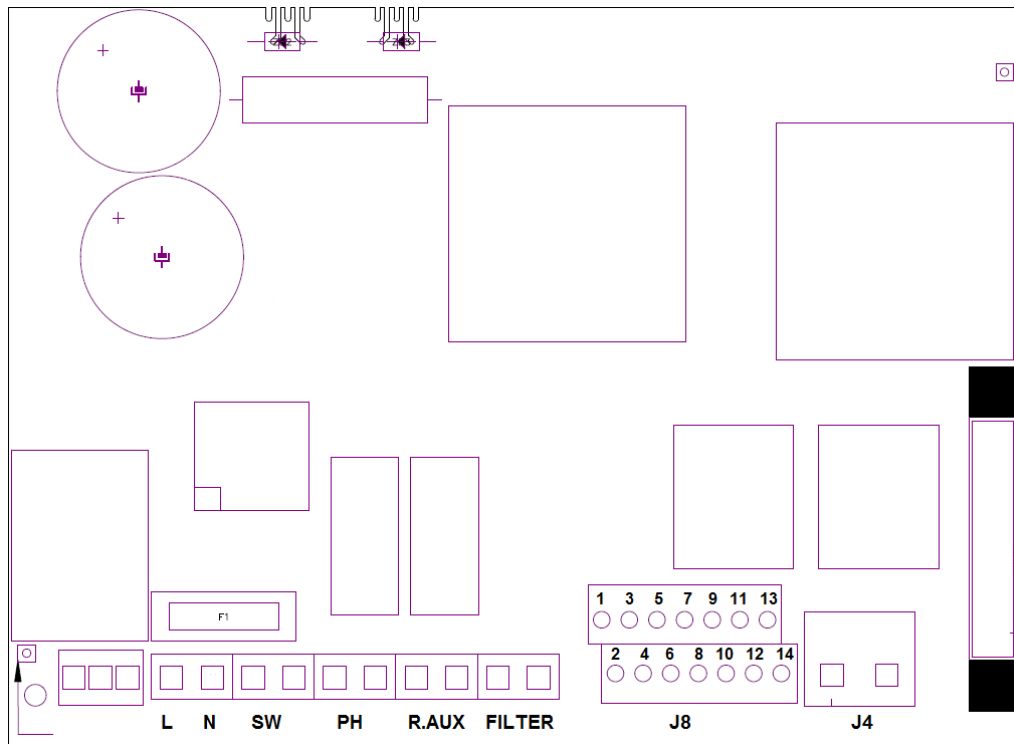

**Earth connection**

**L, N:** Supply 220v

**SW:** On / Off Switch

**PH** pH pump connection (For units with the AUTO kit)

**AUX R:** Auxiliary relay

**FILTER:** Filter connection for Stop / Start mode

**J4:** Terminal block of cell

**J8:**

**1-** (yellow) Acid sensor (PH)

**2-** (yellow) Acid sensor (PH)

**3-** (purple) Cover

**4-** (purple) Cover

**5-** (white) Water sensor (cell's white cable)

**6-** (white) External flow switch (5-6)\*

**7-** (blue) Temperature probe

**8-** (blue) Temperature probe

**9-** (brown) ORP-

**10-** (orange) ORP+ (\*\*)

**11-** (red) 12V free chlorine probe

**12-** (gray) Conductivity probe GND

**13-** (green) Conductivity (signal)

**14-** (red) Conductivity (12v)

\* activate the FLOW SWITCH operation in the configuration menu

\*\* to connect the free chlorine probe, read 3.2.5 chapter

**K1:** PH Relay

**K4:** Auxiliary relay

**LK2:** Stop/Start (see 3.3.3.1)

**F1:** Fuse

### 3.3.2- Advanced Functions

#### 3.3.2.1- Stop-start control

This mode enables you to keep the equipment on permanently, so that when the filtering pump starts up, it will instruct the chlorinator to start-up. When the pump stops, the screen of the chlorinator will display the message "stop".

To activate this mode, remove jumper "LK2" from the power board, supply the chlorinator directly at 230 V, and connect the "filter" inlets in parallel to the supply of the filtering pump. In this way, when the filtration pump turns on, the "filter" input must be connected to 220V, and when the pump stops, "filter" input connector must be at 0V.

## STOP-START CONTROL

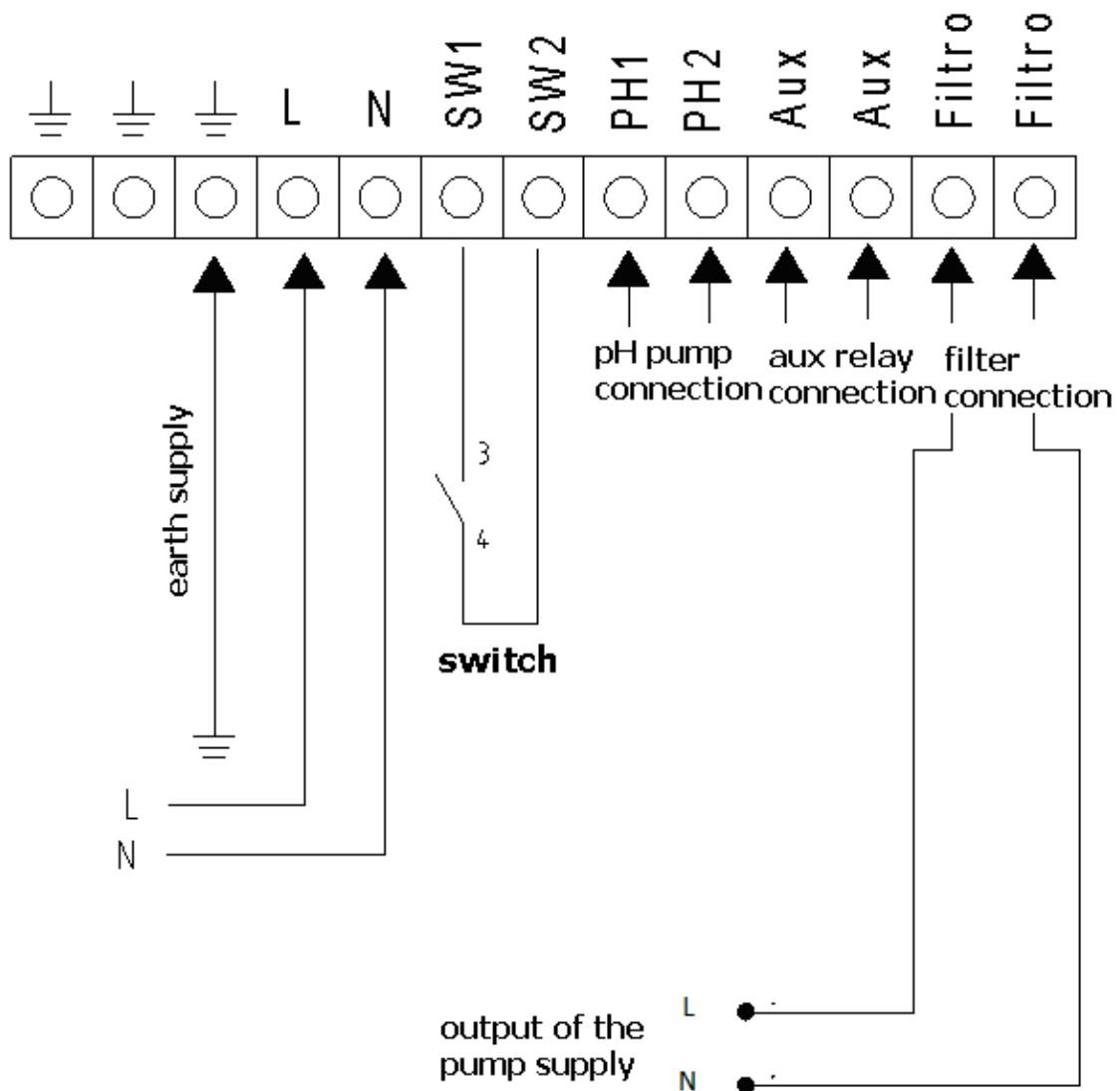

### 3.3.2.2- Programming the spotlights of the pool through the auxiliary relay

The following figure gives an example of use of the auxiliary relay incorporated in the EVO series equipment. Lighting of your swimming pool can be programmed to switch on and off, following this diagram:

#### SPOTLIGHTS CONNECTION

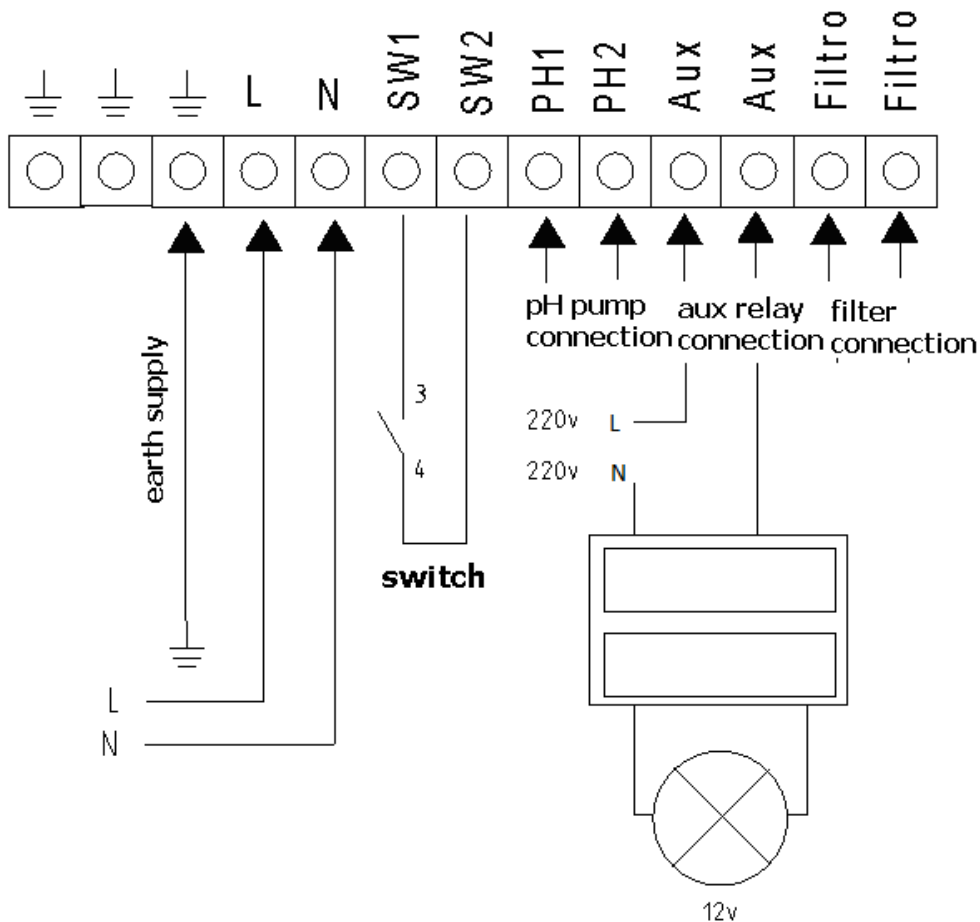

Attention: Never exceed 12A when using the auxiliary relay. For higher currents, supplement the circuit with a contactor.  
Remember that the relay is potential free, and therefore the circuit should be supplied externally.

### 3.3.2.3- Filtering control through the auxiliary relay

The filtering pump can be controlled through the auxiliary relay, following this diagram:

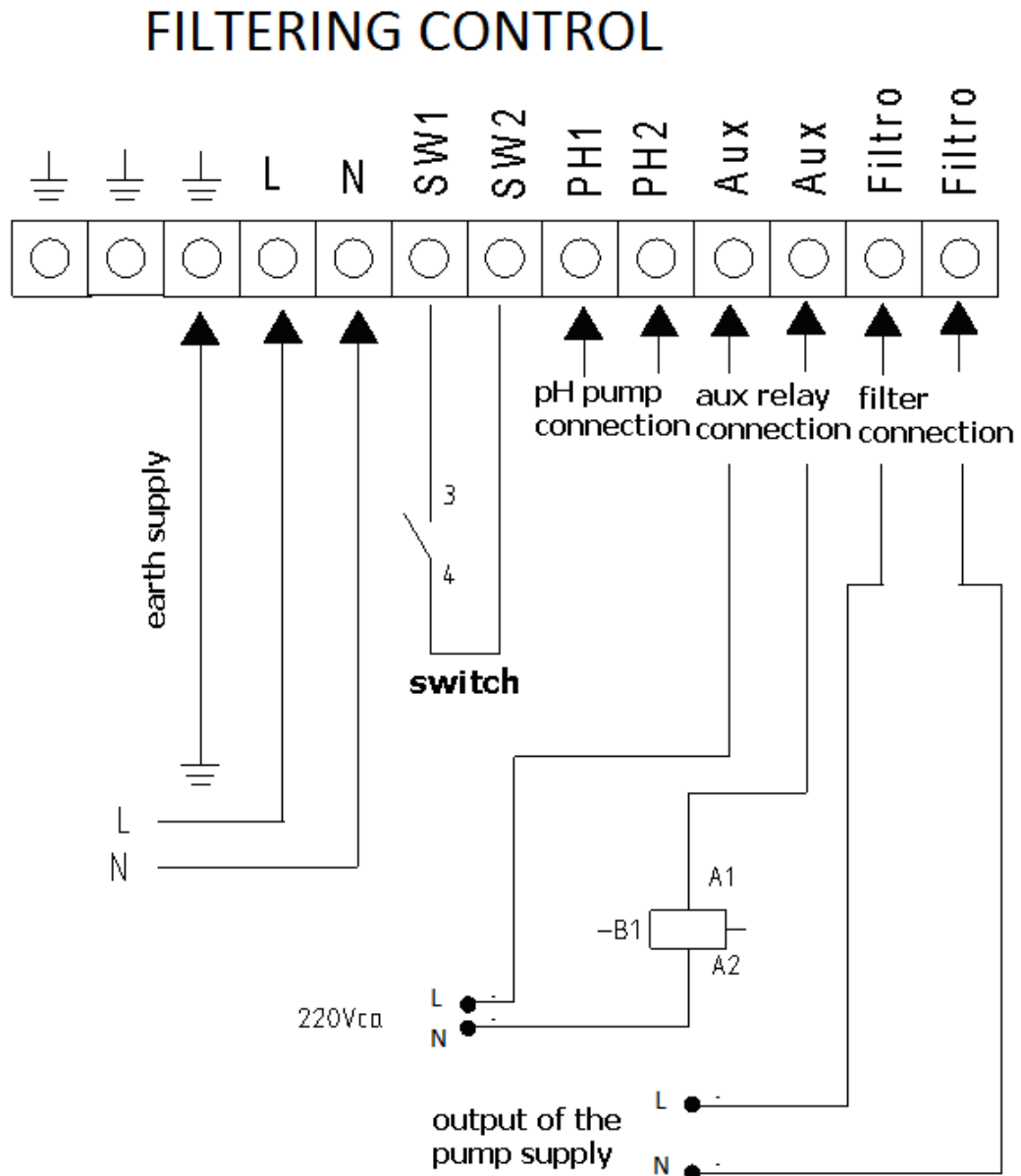

Please remember that the equipment should be configured in "start-stop" mode, as detailed on chapter 3.3.3.1

## 4 - START-UP AND ADJUSTMENTS

Once the BSV salt water chlorinator has been installed, you can start up your salt water chlorination equipment. Follow the instructions carefully. The following sections detail the operation of different models.

### 4.1- EVO series equipment

#### 4.1.1- Operation

The EVO series equipment has an LCD screen, in which you can view and configure all operations of the equipment. The following table shows how to organize the configuration menu of the equipment:

<b>Chlorinating Menu:</b>	<b>Chlorination menu</b>
<b>Main menu</b>	% of production
	Max ORP / CL
Configuration	Super chlorination
Chlorination	(Calibration of free chlorine probe)
pH	
Relay	<b>pH menu</b>
Clock	
Salt	pH +/- (set point value)
	Probe calibration
<b>Configuration menu</b>	Manual pump priming
	On/Off pH
Language	
Control	<b>Relay menu</b>
Cell cleaning cycle	
Volume (m3)	On/Off (START/STOP)
Outdoor/Indoor	Program 1
Cover (N)S	Program 2
Cover(Y) -> Switch N.A	OFF Program
Cover(Y) -> Switch N.C	Timer,min
Flow Switch (N)S	
Acid (Alkali)	<b>Clock menu</b>
pH Alarm (Y)N	
Chloride Alarm (Y)N	Clock (time setting)
22h-9h Alarm	
	<b>Salt menu</b>
	Calibration

When browsing through the menus, an arrow is displayed on the left hand side → which indicates the selected line.

When there is more than one line to select, the buttons ↓ ↑ enable you to move the arrow up or down to select the required option. The **OK** button confirms selection.

When a value has to be adjusted, for example the time or level of chlorine, the buttons ↓ ↑ enable you to increase or decrease the value. Press the **OK** button to confirm the value.

#### 4.1.2- Main screen

On starting up the equipment, a screen will be displayed with the main parameters.

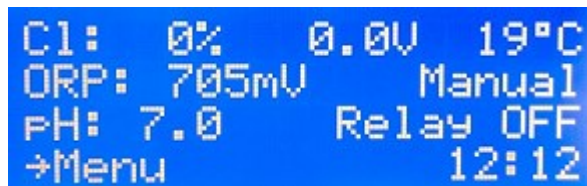

```
Cl: 0% 0.0V 19°C
ORP: 705mV Manual
pH: 7.0 Relay OFF
→Menu 12:12
```

- The upper line displays the production %, the voltage of the electrolysis cell and the water temperature consecutively. (**If you do not have a temperature probe, --- ° will appear**).
- The second line displays the oxidation /reduction potential called RedOx or ORP (Oxidation Reduction Potential) or ppm if working with a free chlorine probe. "Man.", "Auto" or "Semi-auto" is displayed on the right.
- **Important:** If you do not have a RedOx probe or a free chlorine probe, the ORP reading displayed may be a random value. When selecting the Manual mode (this mode is required if it is to operate without a probe), the equipment will ask if you want to display the ORP line or to conceal it.
- The third line displays the pH reading as long as it is fitted in the equipment (EVO model) and the relay status.
- The fourth line displays the →Menu (press the **OK** button to access the menu) and the time on the clock. If any alarm or warning occurs, it will also be displayed on this line.

### 4.1.3- Main menu

Press the "OK" button from the main screen to access the main menu.

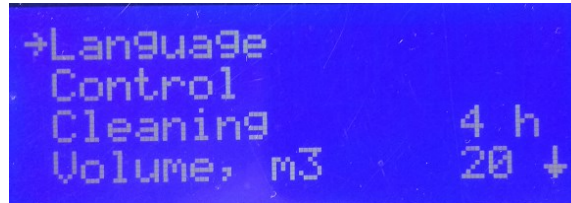

Using the buttons ↓ ↑ you can select a line of the menu, indicated by the arrow (→). The **OK** button is used to confirm the selection. To access the configuration menu, you need to confirm the operation by selecting (S) through the arrow, ↑ and pressing **OK**.

### 4.1.4- Configuration

In the configuration menu you can select the configuration parameters, which usually only have to be adjusted when installing the equipment.



**ATTENTION: A password will be required when trying to change some options of this menu, to avoid an involuntary change of some parameter that could affect to the right behavior of the unit.**

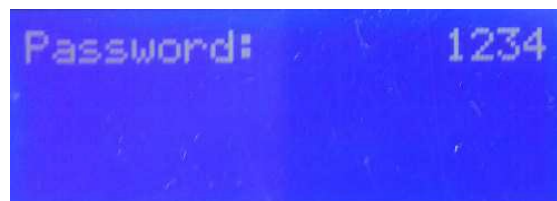

```

→Language
Control
Cleaning          4 h
Volume, m3       20 ↓
    
```

```

→Outdoors        ↑
Cover            N
Flow switch     N
Acid → Alkali   ↓
    
```

```

→Alarm:  pH        Y ↑
Alarm:  Chlorine   N
Alarm:  22h-9h    Y
EXIT
    
```

#### 4.1.4.1- Change of language

From the configuration menu select "Language", press the OK button, and once the required language has been selected, press the **OK** button and **EXIT**.

#### 4.1.4.2- Control

The equipment allows you to select from 4 different modes of control:

©**Manual:** The equipment produces chlorine continuously, depending on the % of production selected. If you have a fitted **ADVANCED** probe Kit probe, it will ignore its value and chlorination will not stop even though the set value has been exceeded. When selecting this mode, the equipment will ask if you want to display the value of the Redox probe (ORP) on the main screen.

**Select this mode if you do not have an **ADVANCED (Redox) probe Kit**,** by adjusting production and hours of filtering depending on the nature of your swimming pool, its volume number of bathers and season of the year.

### ⊙Automatic

**Select this mode only if you have an ADVANCED probe Kit (Redox) or PRO/2 amperometric kit.** If you do not have a probe, the equipment will act at random and end up by stopping and showing an error.

This mode enables you to automatically adjust the level of chlorine in your swimming pool. Based on the adjusted set value in the "chlorine" menu, the equipment will stop when it reaches this value, and start-up again automatically when there is a need for chlorine.

### ⊙Semi-automatic

**Select this mode only if you have a Temperature (NTC/1) probe kit.** If you do not have one, the equipment will not operate correctly in the semi-automatic mode.

This work mode enables you to determine the daily hours of operation of the salt water chlorinator based on the volume in m<sup>3</sup> of the pool and the water temperature. Once they have been reached, the chlorinator will stop although the filtering pump will continue to operate.

Bear in mind that the equipment makes an approximate calculation of chlorine which it has to produce, based on two known parameters. However, other factors are not considered, such as the consumption of chlorine caused by the number of bathers per day.

#### 4.1.4.3- Cleaning

The equipment includes an automatic cleaning system, based on reversing polarity in the electrolysis cell. These cleaning cycles are performed regularly. The time between cleaning (in hours) can be adjusted depending on the water hardness of your swimming pool.

It is possible to select cleaning intervals from 1 to 8 hours.

#### 4.1.4.4 Volume of the swimming pool

Configure the volume of your swimming pool in m<sup>3</sup>, if the equipment is to work in semi-automatic mode. The daily chlorination time will be calculated based on this parameter and the water temperature.

Whenever the value is changed, on exiting the menu the screen will display the minimum filtering time the pump should work.

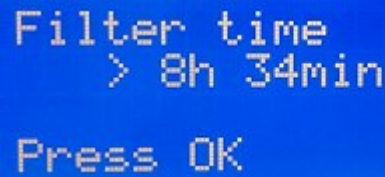

Filter time  
> 8h 34min  
Press OK

If at the end of the day, the filtering pump operates for less time than stipulated by the equipment for an optimum level of chlorine in the water, the equipment will display a warning message.

#### 4.1.4.5 Location of the swimming pool

**Attention: This work mode only affects the semi-automatic operation mode.**

The swimming pool may be installed outdoors or indoors. Function changes between INDOOR and OUTDOOR when the OK key is pressed. With this function, the equipment automatically reduces production to ½ if it is an indoor pool to avoid excess chlorine.

#### 4.1.4.6- Cover

The equipment may detect the presence of a cover on the swimming pool **(only for automatic covers)**. In this case, it is only necessary to place the limit switch of the cover in the terminal block, as indicated in the section on electrical installation.

On placing the cover, the chlorinator automatically reduces production to 20%. This variation will be reflected in the production %, and the letter "C" will be displayed on the right side of production in the main screen. This will indicate that the cover is activated.

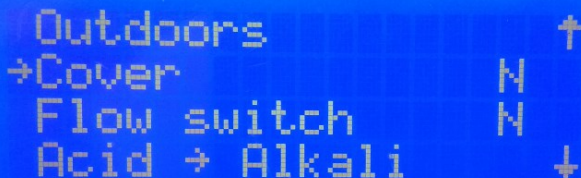

Outdoors ↑  
→Cover N  
Flow switch N  
Acid → Alkali ↓

Once the cover detection is activated, the system will ask which is the type of sensor you have installed: Normally open (N.O.) or Normally Closed (N.C.)

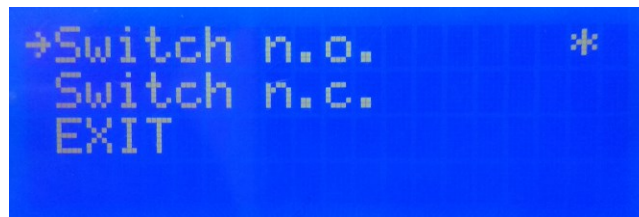

If chlorination is carried out with the cover in place, when it is removed, the pool should not be used straightaway. It is better to wait ½ hour for any vapours between the water and cover to dissipate.

**Note: Password "1234" is required to modify this function.**

#### 4.1.4.7 Flow switch

The flow sensor detects whether or not there is water flow in the piping. If it detects that there is no flow, the production will stop, and an alarm will sound accompanied by a red warning LED. Once the flow has been reestablished, the equipment will return to normal operation.

The "Flow Kit" (**optional**) is necessary to activate the flow sensor, which is done by pressing OK in the menu **Flow Switch = Y**.



**Note: Password "1234" is required to modify this function.**

#### 4.1.4.8 Acid / Alkali

With this option you can select the type of pH corrector to be used in your swimming pool.



**Attention: It should be selected correctly otherwise the dosing system will work opposite to expected.**

- Acid: Select this mode if you are going to inject pH reducer into the swimming pool (default mode).
- Alkaline: Select this mode if you need to inject pH increaser into the swimming pool.

Access this option from the "Configuration menu". To change this mode to another one, press OK and confirm the change of mode by selecting "S" and then press OK again.

**Note: Password "1234" is required to modify this function.**

#### **4.1.4.9- pH Alarm**

The pH adjustment system will give an alarm and the dosing pump will stop operating when the pump works continuously for more than 2 hours,

This could occur for the following reasons:

- The acid tank is empty and therefore pH corrector is not being injected into the swimming pool.
- The pH probe is dirty or worn, and cannot read the real value correctly.

However, what could occur, particularly when starting up the equipment for the first time, is that the real pH of the water is a long way from the set value. The alarm can be disabled if it is calculated that the pump needs to work continuously for several hours to correct the pH. However it is recommended to enable the alarm once values near the set values are reached.

**Note: Password "1234" is required to modify this function.**

#### **4.1.4.10 Chloride Alarm**

When the unit is configured in automatic mode, it is possible to disable the "Chloride Alarm". This alarm will detect if the ORP or PPM reading hasn't changed for two hours or more, despite the unit has been in production.

Despite this alarm is been implemented to detect if a probe is not in good conditions, or there is some chemical issue in the water, it can be disabled if the user wants to maintain the production despite everything.

**Note: Password "1234" is required to modify this function.**

#### 4.1.4.11 Night Alarm (22h-9h)

When an alarm occurs, the unit stops its production and shows an acoustic and visual alarm to indicate that it's necessary to correct the problem.

However, it is possible to keep the alarm silent between 10:00 pm and 9:00 am, selecting the option Night Alarm = N

#### 4.1.5- Chlorine menu

With this menu you can select all parameters related to chlorine production.

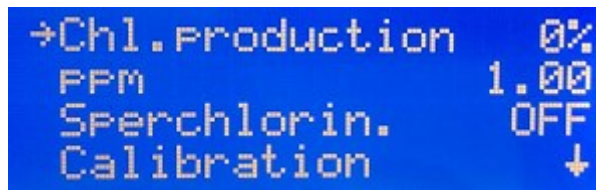

```
→Chl. Production    0%
  PPM                1.00
  Superchlorin.     OFF
  Calibration        ↓
```

##### 4.1.5.1- Production of cl.

Configuration of the maximum production of chlorine.

From 0% to 100% Press "OK" and use the arrows ↓ ↑ to change the value. Press "OK" to confirm the adjustment.

Note: Chlorine production may be limited regardless of the operation mode (manual, automatic...) that is selected.

##### 4.2.5.2- Adjustment of the set value (Max. ORP or Max. PPM)

**ORP Mode** in which a Redox probe (OPTIONAL) is installed.

In this case, adjust the oxidation potential to the required level. For private swimming pools that are not used frequently, 650 mV is a sufficient value 700 mV is the suitable value for the majority of swimming pools. Press "OK" to confirm the adjustment. However, the best way to adjust the optimal ORP value is to analyze the water and determine the ratio between ORP and PPM, because there are some differences between several types of water.

NOTE: if working in automatic, you can also adjust the production percentage from 0% to 100%,

**PPM Mode** in which a free chlorine probe (OPTIONAL) is installed.

In this case, adjust the value in ppm as required. A value between 1ppm and 1.5ppm is correct.

NOTE: if working in automatic, you can also adjust the production percentage from 0% to 100%,

**On connecting the equipment in automatic mode, the ORP/PPM value will flash for 5 min before the equipment starts to produce chlorine.**

#### **4.1.5.3- Super chlorination**

Select this option if you require super-chlorination of your swimming pool, bearing in mind the following:

- If the equipment is working in semi-automatic mode (**with the NTC PROBE KIT**), the equipment will calculate the time necessary depending on the volume and Temperature. The filtering time to perform super-chlorination will be displayed on the screen.
- Without a Temperature probe, super-chlorination will be carried out for 24 hours. If filtration is stopped, super-chlorination is suspended.

#### **4.1.5.4- Calibration of the free chlorine probe**

If you have a free chlorine probe, a menu will appear for you to calibrate it.

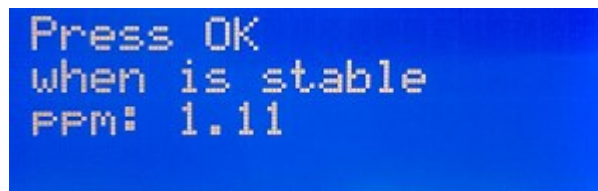

```
Press OK
when is stable
PPM: 1.11
```

Once the reading has stabilized and the chlorine measurement has been taken with **DPD1**, adjust the **PPM** value provided by the DPD1 measurement.

#### **4.1.6- pH menu**

With this menu, you can adjust the parameters related to the pH adjustment of your swimming pool. It only appears in EVO series equipment.

##### **4.1.6.1- Main screen**

The reading of the pH probe can be seen in the 3rd line of the main screen.

```

Cl: 0% 0.0V 19°C
ORP: 705mV Manual
pH: 7.0 Relay OFF
→Menu 12:12
    
```

**pH adjustment does not start up until 5 minutes after the equipment has been switched on.**

A proportional control automatically adjusts the pH without the need for controller adjustments. The pump will start up every minute and with a variable operation time of between 0 and 60 seconds.



**ATTENTION: It is required to do a pH probe calibration during the equipment installation. New calibration should be done on changing or cleaning the probe.**

#### 4.1.6.2- Access to the pH Menu

You can access the pH menu from the main menu by pressing **OK**

```

→pH +- 7.3
Calibration
Manual
pH ON/OFF ON ↓
    
```

#### 4.1.6.3- pH Adjustment

Go to the main menu, select "pH" and in the pH menu that is displayed, select "pH +-"

Use the buttons **↑↓** to adjust the required pH and confirm with "OK".

#### 4.1.6.4- Calibration of the pH probe

To calibrate the probe, prepare a glass with clean water. Remove the probe from the storage liquid, shake off the liquid and stir it in the water. Shake it again to remove the water. Dry with a clean cloth, without rubbing.

In the control, go to "Menu" – "pH" – Calibration. The 1st line of the display indicates "pH cal. = 7" . Submerge the probe in the pH7 standard solution and stir for a few seconds. The second line of the display indicates the measured value of pH. Wait until the reading stabilizes and then wait for at least one more minute. Press the "OK" button.

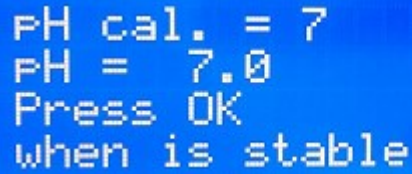

```
PH cal. = 7
PH = 7.0
Press OK
when is stable
```

The first line of the screen now asks you to use the pH4 standard solution. Remove the probe from the first solution, shake it and pass it through the water. Remove this water by shaking the probe again. Finish rinsing it gently with a clean cloth, without rubbing. Submerge it in the pH4 standard solution.

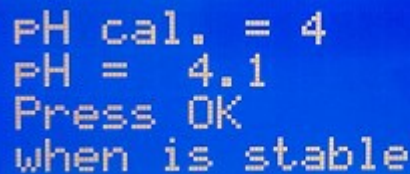

```
PH cal. = 4
PH = 4.1
Press OK
when is stable
```

Wait until the reading stabilizes and then wait for at least one more minute. Press the "OK" button. The message "Calibration OK" will appear.

Press "OK". If an error message appears, it could be because a probe is dirty (see maintenance) or faulty, or because of contaminated standard solutions or a faulty connection. Carry out two calibrations for a better reading of pH.

If you have entered the calibration program by error, exit it by pressing "OK" several times. The error message is shown and the previous calibration remains unaltered.

#### **4.1.6.5- Switching the pH adjustment on and off**

To switch off or start-up the pH control again stopping the acid pump, access the main menu, select "pH" in the last line. In the pH menu select the bottom line. By pressing "OK", it alternatively passes from "pH ON" to "pH OFF".

When the pH control is off, the 3rd line of the screen displaying the parameters indicates "pH OFF".

#### **4.1.6.6- Priming the pump.**

Once the acid pump has been installed, it should be primed to eliminate the installation air.

Go to the "pH" menu and select "Manual". Keeping the "OK" button pressed, the pump will be running. Keep the pump running with the "OK" button until the liquid has passed throughout the tube until injection.

#### 4.1.6.7- Acid - Alkaline

Access the configuration menu of the equipment to pass the pH control from acid to alkaline. To do this, press "OK" in the main screen, in configuration "S" press button ↓ until reaching the ACID line. Press "OK" and the letter "N" will appear with the arrow ↓. Select "S" to remain in the ALKALI screen.

#### 4.1.6.8- Automatic shutdown and error message.

If the acid pump shuts down and the message "pH ERROR" appears, the pump has been operating too long without the pH value lowering to the required level. The causes could be:

- There is no acid.
- Problem in the pump or in the acid duct.
- The probe or probe cable are damaged.

**NOTE: to cancel the error alarm, press the "OK" button**

#### 4.1.7- Relay

The EVO series equipment has a programmable auxiliary relay that can be used to control the filtering pump, swimming pool lighting and others features See pages 23 and 24 of this manual for further details.

##### 4.1.7.1- Start/Stop

This manually turns the relay on / off.

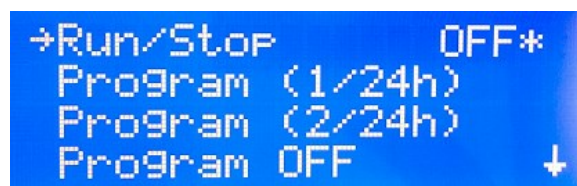

→Run/Stop OFF\*  
Program (1/24h)  
Program (2/24h)  
Program OFF ↓

##### 4.1.7.2- Program (1/24h)

This allows one single programming a day from 0h to 23.59.



Run: 0:00  
Stop : 0:00  
↑↓ = EXIT

#### 4.1.7.3- Program (2/24h)

This allows two individual daily programs

```

1 Run:           :00
1 Stop :         0:00
2 Run:           0:00
2 Stop :         0:00
    
```

#### 4.1.7.4- Program OFF

Cancels and details the programs carried out.

#### 4.1.8- Clock

The equipment has a time clock, which will be taken as the reference when programming times of the auxiliary relay. The clock keeps the time setting even when the equipment is without supply.

```

→Time           12:32 ↑
EXIT
    
```

### 4.2- Warning messages and alarms (EVO)

In the event of abnormal operation, the EVO series equipment will display an **alarm** message on the 4th line of the screen, together with an acoustic warning. The alarms shutdown the equipment until the problem is solved. Similarly, it will display a **warning** also in the 4th line, but without an acoustic signal or shutting down the equipment. In this case, the equipment can continue operating, although you are informed that corrective action should be taken.

#### 4.2.1- Warnings

Message:	Causes:	Action required:
"LACK OF SALT"	Lack of salt in the water.	Add salt to the swimming pool.
	Incrustations or objects in the electrolysis cell causing lack of current.	Clean the cell.
	The electrolysis cell is worn.	Replace the electrolysis cell with a new one.

"EXCESS SALT"	Excess salt in the water.	No action required if excess is not very significant.
	Incrustations or objects in the electrolysis cell causing excess current.	Clean the cell.
"CLEANING"	The chlorinator is in the self-cleaning process. The process lasts 5 minutes	None.
"TEMPERATURE".	The ambient temperature is >40°	Try and place the equipment in another position where it is not over 40° or perform forced ventilation. Leave the equipment to rest for a few minutes. Consult section number 4. Installation
	The radiator fins are obstructed or are not in a vertical position.	Place the equipment so that air is circulated for correct cooling.

#### 4.2.1.1- Additional warning messages

ORP or PPM value is flashing	The redox or free chlorine probe are balanced in automatic mode. When the probe is balanced, the value remains set.	None.
pH value is flashing	The pH probe is balancing. When the probe is balanced, the value remains set.	None.
Value ---o (Water temperature) is flashing	The value of the water temperature is under 15°.	Consider the use of a winter hibernator product.
Filter time	The equipment has switched off before the time set in semi-automatic	Restart the filtering cycle

#### 4.2.2- Alarm Messages

<b><i>In the following cases, the chlorinator shuts down and the alarm and acoustic alarm LED is activated (automatic reset once the fault is solved):</i></b>		
"NO WATER FLOW"	Excess gas in the electrolysis cell. It may have occurred because the pump has shutdown. The gas is hydrogen gas which is highly flammable.	The piping should be drained to eliminate gas or accumulated water. Check the pump.
	Sensor cable of the cell is incorrectly connected or broken.	Check the sensor cable (white cable)
	Cell sensor is dirty.	Clean. See maintenance.
	No water flow	Check the water system
"SHORT CIRCUIT"	The cell is incorrectly connected.	Check wiring.
	Metal body in the cell.	Turn off the equipment and remove the metal body from the plates
"OPEN CIRCUIT"	Cell is incorrectly connected.	Check the cell connection and ensure that cables and connection terminals are in good condition.
	Cell is damaged or completely worn down.	Check the condition of the cell electrodes, and replace it if any damage is observed.
	Swimming pool water with very low salt concentration.	Ensure that the water has salt and that it is dissolved.
"Chl. error"	Chlorine probe is incorrectly connected or damaged	Check the cabling of the probe and the probe itself. Check 5.1. It can work in manual mode if necessary.
	Water contains very low redox potential.	Leave the equipment to chlorate in manual mode for at least 2 hours. Check the chemical balance of the water. (appendix 1)
	The equipment does not have a probe and is in "automatic mode".	Install a Redox or Free Chlorine probe, or configure "manual" mode.

### 4.3- Operation time

It may be useful to see the operation times for regular maintenance operations. From the main screen, press both buttons ↓ ↑ at the same time.

### 4.4- Electrolysis cell life

The electrolysis cells from our units are designed to reach a lifespan of 10.000 hours (10K models) and 5.000 hours (5k models). However, this lifespan is directly related with the quality of the water and specially with the correct use of the equipment. Please, read the following suggestions in order to guarantee that your cell reaches the specified lifespan.

- a) **Salt concentration:** It is very important that the water of your swimming pool has a sufficient salt concentration, otherwise the cell will degrade prematurely if you keep it working permanently in low salt conditions. It is important to add salt when the unit shows the "lack of salt" indication.
- b) **Low temperature operation:** Don't keep the system work in low water temperature conditions (under 15°C). As an alternative, there are some hibernation products that keeps the water in good conditions in winter time. If you still want to use it in low water conditions, please consider to reduce the maximum production value, for example, set it at 50% instead of 100%.
- c) **Automatic cleaning cycles:** The time between automatic cleanings can be adjusted in Evo units, so it can be adapted to the water hardness of your swimming pool. The chlorinator is configured by default to 4 hours. If your swimming pool water is very hard, you can decrease this value, so the automatic cleanings will perform more frequently, but the lifespan of the cell will be reduced. On the other hand, if the water is soft, you can increase the cleaning time cycle, and the cell's lifespan will be increased.
- d) **Deficient cleaning:** If you observe calcium deposits between the cell electrodes, clean it as shown in the 5.1 section. Don't allow to keep the cell working in these conditions for a long time.

## 5 - MAINTENANCE

Carefully follow the recommendations and safety warnings detailed in section 1.4 of this manual.

The chlorinator has a self-cleaning system of the chlorination cell, which reduces maintenance considerably. In any event, it is advisable to clean the cell and check the chlorine (Redox), free chlorine or pH probe if available.

Bear in mind that both the electrolysis cell and the REDOX probe wear out through use. If after cleaning, the equipment does not work normally, the

probe or cell should be replaced. Your dealer will be able to advise you on the need to change these elements.

### **5.1- Cleaning the electrolysis cell**

The electrolysis cell should be cleaned in the following circumstances:

- If the low level of salt indicator comes on and the concentration is correct.
- If the overload indicator comes on and the level of salt is correct.
- If lime scale is observed on the surfaces of the electrodes. In this case, the equipment can also be adjusted so that the frequency between each automatic cleaning operation is less. This frequency will depend on the hardness of water in your area.

Submerge the cell in a hydrochloric acid solution, or use a commercial product to clean electrolysis cells (CELLCLEAN). Do not use sharp objects that could damage the titanium coating of the electrodes.



### **5.2- Checking and maintenance of the Redox probe (OPTIONAL)**

Select *Menu*, and *Man. Chl.*

Adjust the chlorine to 0%. Go back to the display screen.

Rinse the probe carefully in clean water.

Insert the probe into a 465mV standard solution and stir gently. Observe the voltage on the label, which corresponds to the ambient temperature at that time. Wait for the reading of the ORP value displayed on the screen to stabilize.

Check that the value does not differ by more than about 10 mV of the value indicated on the label. If the value is incorrect, it can be attempted to regenerate the probe by cleaning it. In any event, annual cleaning is always advisable.

- Stir the probe in a glass of water, in which a spoonful of dishwashing detergent has been mixed. Rinse well in clean water.

- Mix a commercial brand of hydrochloric acid at 23% in a glass, with four times its volume of water. Leave the probe in the solution for a few minutes, stirring from time to time.
- Thoroughly clean the probe in pure, preferably distilled water. Shake the probe to remove the water.

Recheck the value of the probe. A probe that gives an error lower than around 30 mV can continue to be used provisionally while it is replaced.

Never leave the probe outside. If the probe has been dry for a time, it can be regenerated with the hydrochloric acid solution.

### 5.3- Checking and maintenance of the pH probe

It is recommended to clean and check the probe at least once a year. Stir it in a glass of water in which a spoonful of detergent has been dissolved. Then wash it under the tap and leave it for a few hours in a glass of water in which 1 cm<sup>3</sup> of hydrochloric acid has been added.

Recalibrate the probe again.

If well maintained, a probe can last for two or three years.

The probe should never be left to dry. If it is kept outside the installation, the original cap should be placed, or it should be submerged in a glass of water. If a probe has been left to dry, it can be regenerated by leaving it for 12 hours in a glass of water, preferably adding a few drops of hydrochloric acid.

### 5.4- Checking and maintenance of the Amperometric probe (PRO/2 kit)

Please, read carefully the 3.5.2 section of this manual.

To locate any possible problems, you can follow the recommendations in the following table:

PROBLEMS	CAUSE	SOLUTION
Reading = 0, does not coincide with the DPD-1 measurement	Failure in the connection of the sensor with the controller	Check connections
	Insufficient flow in the sensor holders or the chlorine sensor is not in contact with the water	Adjust the flow reaching the sensor holders. Clean the filter and the flow regulator of the sensor holders

	There are air bubbles in the measuring zone of the sensor	Bleed the sensor holder and ensure that there is no air remaining in the measuring zone.
	The sensor has been a number of hours measuring the water without free chlorine	Let water containing free chlorine circulate through the sensor holders for 1 hour.
Reading below the DPD-1 measurement	Insufficient flow in the sensor holders	Adjust the flow reaching the sensor holders. Clean the filter and the flow regulator of the sensor holders.
	There are air bubbles in the measuring zone of the sensor	Bleed the sensor holders and ensure that there is no air remaining in the measuring zone.
Reading above the DPD-1	The sensor has been calibrated without waiting for sufficient conditioning time	Repeat conditioning of the sensor and recalibrate.
	DP-! Reactives are worn	Repeat the DPD-1 measurement with new reactives
Unstable reading	Failure in the connection of the sensor with the controller	Check connections
	The water flow reaching the sensor holders is unstable and the flow regulator is not operating.	Stabilize pressure in the piping where samples are taken for the sensor holders and check the flow regulator.

There are air bubbles in the measuring zone of the sensor	Bleed the sensor holder and ensure that there is no air remaining in the measuring zone.

## 6 - GUARANTEE AND SERVICE

**This unit is guaranteed for a period of 3 years in control main unit.**

**The electrolysis cells have a control of two years, as long as they have not exceeded 10,000 hours of use (10K models) and 5.000 hours (5K models).**

This guarantee is given to the owner of the equipment and it is not transferable. All chlorinators are checked at the factory before packing. If any electrical or mechanical problems occur within 24 months from purchase, owing to unlikely malfunctioning or to faulty components, the parts will be repaired or changed. A part will not be changed unless the faulty component is returned.

This guarantee does not cover damage caused by corrosion, excess damp, current, temperature or vibration, or by incorrect installation, unsuitable handling, overvoltage, accidents or any other cause beyond the operation of the equipment.

In the event of an equipment failure, it should be returned to the manufacturer or distributor. Transport costs will be covered by the equipment owner.

**It is important to bear in mind that all repairs under guarantee are performed at the factory, or by an authorized BSV Electronic technical service.**

